

'Piranha Off Road products are not associated in any way with MITSUBISHI Motors Australia Ltd or any of its related companies'

To Suit MITSUBISHI PAJERO NA - NG 4D56 2.5D / 4D56T 2.5TD

PART NUMBER	BTMPO
APPROX FITTING TIME	1 Hour
MAX BATTERY SIZE	235mm Long
RECOMMENDED TYPE	Cycle Duty
TRAY LOCATION	PSF

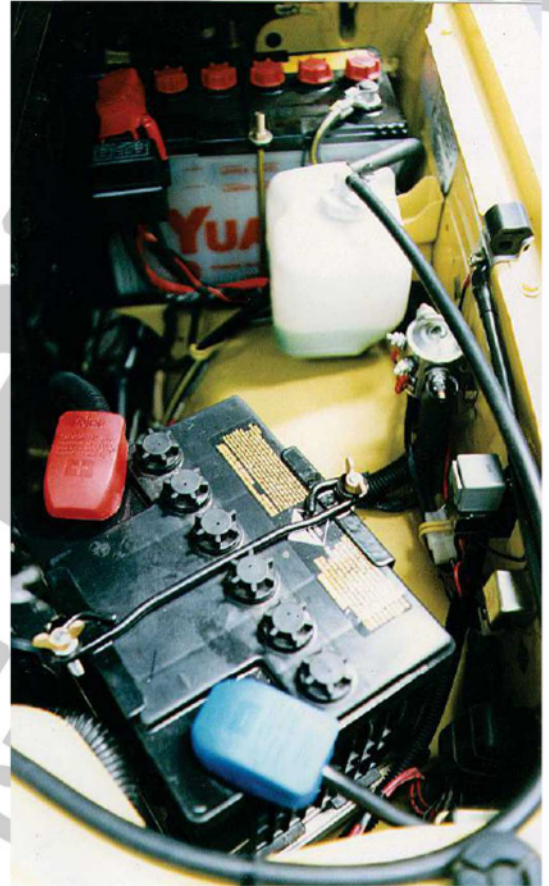
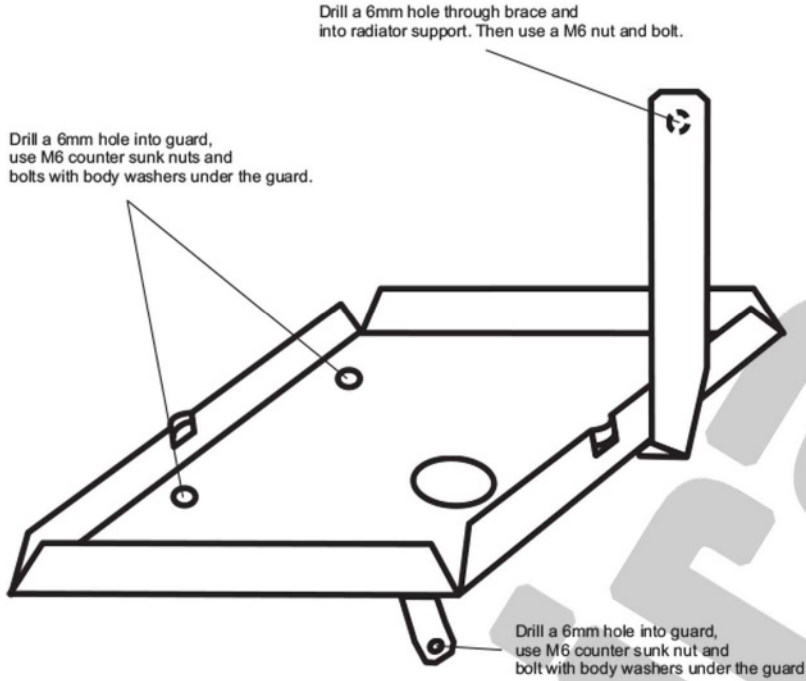

PARTS INCLUDED WITH TRAY

- 2 X M6 Bolt
- 2 X M6 Bolt Countersunk
- 4 X M6 Nuts
- 3 X Body Washers
- 2 X J Bolts
- 1 X Universal Top Mount

RECOMMENDED ISOLATOR

DBE140SF
or
DBE180-SX

FITTING INSTRUCTIONS

The cradle fits passenger side front.

Air conditioning pipes may have to be slightly modified for fitment of cradle. A vacuum sensor may also have to be moved. The top brace of the cradle rests flush with the radiator support bracket and is bolted. The two counter sunk holes are drilled into the guard, using a 6mm drill. Fasten with counter sunk bolts and use body washers and 6mm nuts. Now drill the lower support with a 6mm drill. Use a M6 nut and bolt with a body washer, under the guard. The top brace, which uses the radiator support, has to be positioned so that the cradle is level. A clamp may be of some assistance when you do this. Then drill a 6mm hole through brace and radiator support. Use a M6 nut and bolt to fasten brace.

Ensure, before closing the bonnet that all items fitted have adequate clearance